

### 7. SPD Series (Shielded Type)

#### Applications

- Power supply for VTRs.
- Personal & Notebook computers.
- Smart Home Systems.
- Other various electronic appliances.

#### Features

- Compact, low profile with Rdc and large current.
- With magnetic shielded against radiation.
- Flat bottom surface allows reliable mounting onto the board.
- High power, high saturation inductors.



#### Inductance and Rated Current ranges

Part Series	Inductances range	Rated Current range
* SPD0628	1.0~1000μH	2.10~0.12A
* SPD0732	1.0~1000μH	2.40~0.20A (I <sub>rms</sub> ) ; 2.20~0.13A (I <sub>sat</sub> )
* SPD0745	1.0~1500μH	3.50~0.15A (I <sub>rms</sub> ) ; 4.00~0.10A (I <sub>sat</sub> )
* SPD1045	1.0~1500μH	12.00~0.40A (I <sub>rms</sub> ) ; 7.80~0.22A (I <sub>sat</sub> )
* SPD1255	6.0~1500μH	4.90~0.48A (I <sub>rms</sub> ) ; 3.60~0.29A (I <sub>sat</sub> )
* SPD1265	2.0~150μH	8.00~0.80A (I <sub>rms</sub> ) ; 10.00~1.00A (I <sub>sat</sub> )
* SPD1275	1.2~330μH	10.40~0.88A (I <sub>rms</sub> ) ; 13.00~1.10A (I <sub>sat</sub> )

(Dimension data (Refer to Fig. 1))

#### Characteristics

Test Frequency : 1.0KHz 0.5V

- Saturation Rated Current (I<sub>sat</sub>) : The current when the inductance becomes 30% lower than its nominal value.
- Temperature Rated Current (I<sub>rms</sub>) : The actual current when the temperature of coil becomes to T=40 . (T<sub>a</sub>=25 )

Operating temperature range : -40 ~+125 .

Test equipment :

L: HP4284A LCR meter.

DCR: Milli-ohm meter.

Electrical specifications at 25 .

#### Part Numbering System

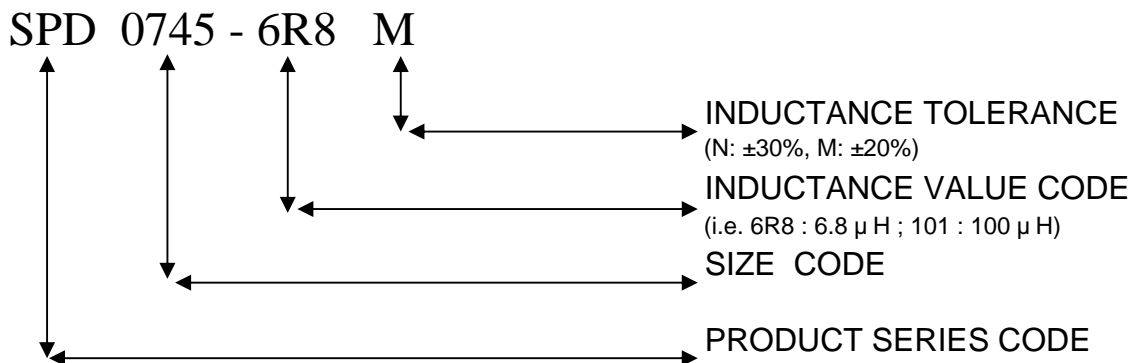

7. SPD Series (Shielded Type)

**Dimensions (mm)**

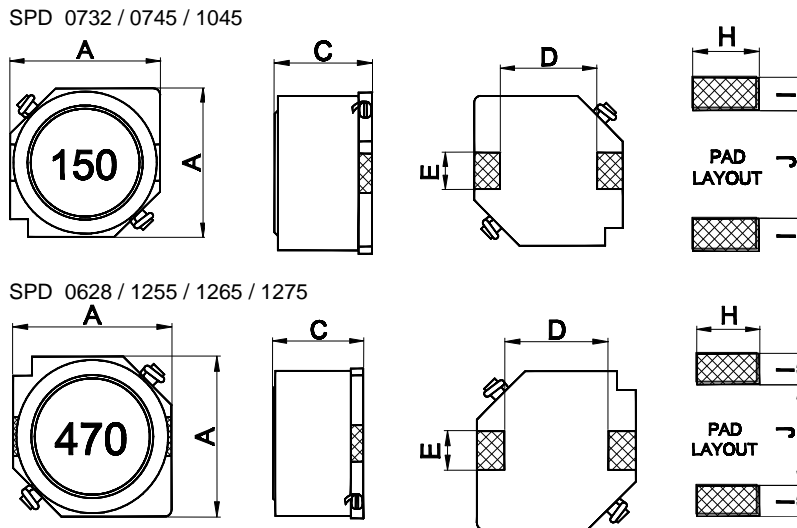

Fig. 1

Series	A	C	D	E	H	I	J
SPD0628	6.00±0.20	2.80±0.20	4.00	2.00	2.20	1.50	4.00
SPD0732	7.00±0.20	3.20±0.20	4.00	2.00	2.20	1.50	4.00
SPD0745	7.00±0.20	4.50±0.30	4.00	2.00	2.20	1.50	4.00
SPD1045	10.10±0.30	4.50±0.30	6.00	3.00	3.20	2.50	5.60
SPD1255	12.50±0.30	5.50±0.35	8.60	3.00	3.20	2.50	8.60
SPD1265	12.50±0.30	6.50±0.35	8.60	3.00	3.20	2.50	8.60
SPD1275	12.50±0.30	7.50±0.35	8.60	3.00	3.20	2.50	8.60

7. SPD Series (Shielded Type)

Electrical Characteristics

SPD 0732 / 0745 / 1045 TYPE

Inductance Value Code	Tol.	L (μH)	DC Resistance ( ) ±20%			Rated DC Current (A) Max.					
						I rms			I sat		
			0732	0745	1045	0732	0745	1045	0732	0745	1045
1R0	M	1.0	0.019	0.019	0.012	2.40	3.50	12.00	2.20	4.00	7.80
1R2	M	1.2	-	0.019	-	-	2.80	-	-	3.20	-
1R5	M	1.5	-	-	0.014	-	-	7.00	-	-	5.80
2R2	M	2.2	0.021	-	0.015	2.10	-	7.00	2.00	-	5.60
3R3	M	3.3	0.023	-	0.016	2.00	-	6.00	1.90	-	5.10
3R9	M	3.9	0.029	-	0.018	2.00	-	6.00	1.85	-	4.10
4R7	M	4.7	0.036	0.029	0.020	1.90	2.10	5.50	1.70	2.00	3.70
5R6	M	5.6	0.039	-	0.022	1.80	-	5.00	1.65	-	3.40
6R8	M	6.8	0.041	0.039	0.025	1.80	1.74	4.00	1.60	1.70	3.20
8R2	M	8.2	0.049	-	0.027	1.70	-	4.00	1.50	-	3.10
100	M	10.0	0.053	0.036	0.036	1.50	1.70	3.50	1.40	1.30	3.00
120	M	12.0	0.071	-	0.033	1.30	-	3.50	1.20	-	2.50
150	M	15.0	0.075	0.052	0.047	1.20	1.53	3.00	1.10	1.10	2.40
180	M	18.0	0.099	-	0.052	1.20	-	3.00	1.00	-	2.20
220	M	22.0	0.110	0.061	0.059	1.00	1.34	2.50	0.96	0.90	2.10
270	M	27.0	0.150	-	0.073	1.00	-	2.50	0.85	-	1.70
330	M	33.0	0.160	0.096	0.082	0.90	1.09	2.00	0.75	0.82	1.60
390	M	39.0	0.230	-	0.099	0.82	-	2.00	0.70	-	1.50
470	M	47.0	0.240	0.125	0.100	0.80	0.92	1.50	0.67	0.75	1.40
560	M	56.0	0.300	0.130	0.110	0.80	0.85	1.50	0.60	0.67	1.30
680	M	68.0	0.310	0.200	0.140	0.62	0.77	1.50	0.59	0.60	1.20
820	M	82.0	0.424	0.244	0.190	0.60	0.70	1.40	0.49	0.52	1.10
101	M	100.0	0.450	0.250	0.200	0.55	0.65	0.90	0.45	0.50	1.00
121	M	120.0	0.620	-	0.280	0.50	-	0.90	0.40	-	0.80
151	M	150.0	0.650	0.480	0.350	0.50	0.55	0.85	0.37	0.40	0.79
181	M	180.0	1.020	-	0.420	0.45	-	0.90	0.30	-	0.69
221	M	220.0	1.050	0.850	0.470	0.40	0.45	0.90	0.29	0.33	0.65
271	M	270.0	1.530	-	0.620	0.40	-	0.80	0.24	-	0.55
331	M	330.0	1.670	1.100	0.680	0.35	0.37	0.70	0.22	0.25	0.54
391	M	390.0	1.990	-	0.900	0.35	-	0.60	0.21	-	0.49
471	M	470.0	2.050	1.050	1.030	0.30	0.31	0.60	0.20	0.22	0.47
561	M	560.0	3.100	-	1.300	0.29	-	0.50	0.17	-	0.40
681	M	680.0	3.150	2.080	1.600	0.25	0.27	0.50	0.16	0.20	0.38
821	M	820.0	4.500	-	1.800	0.24	-	0.45	0.14	-	0.33
102	M	1000.0	4.780	2.280	2.800	0.20	0.25	0.40	0.13	0.14	0.32
152	M	1500.0	-	3.500	3.400	-	0.15	0.40	-	0.10	0.22

Test Frequency : 1.0KHz 0.5V

1. Saturation Rated Current (I sat) : The current when the inductance becomes 30% lower than its nominal value.

2. Temperature Rated Current (I rms) : The actual current when the temperature of coil becomes to T=40 (Ta=25 )

Operating temperature range : -40 ~+125 .